

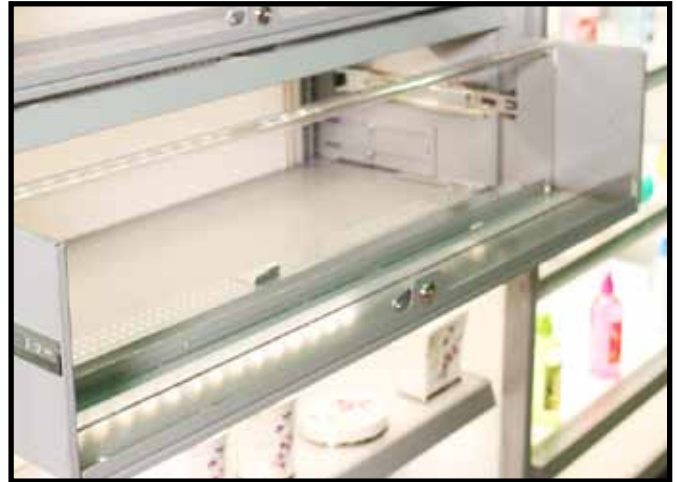

**madix**

INNOVATION ON DISPLAY







Madix's new Vesta™ fixture creates a high end, custom appearance. Vesta's optionally equipped LEDge Lights and acrylic shelves draw attention to merchandise by allowing lighting to fully penetrate the fixture's surfaces. When lit, it glows. Additional options include Base Drawers and Base Display Tables. It's ideal for many market segments, especially health and beauty, home goods, kitchenware, and apparel.

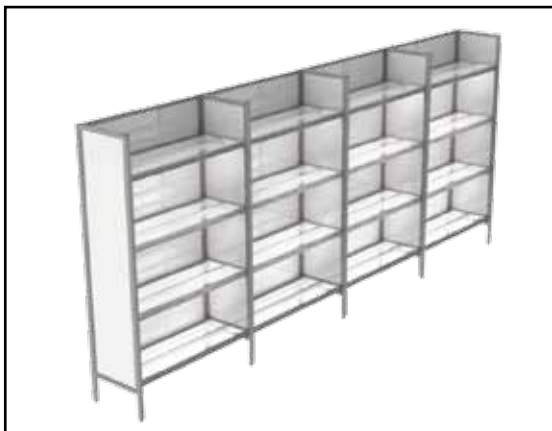

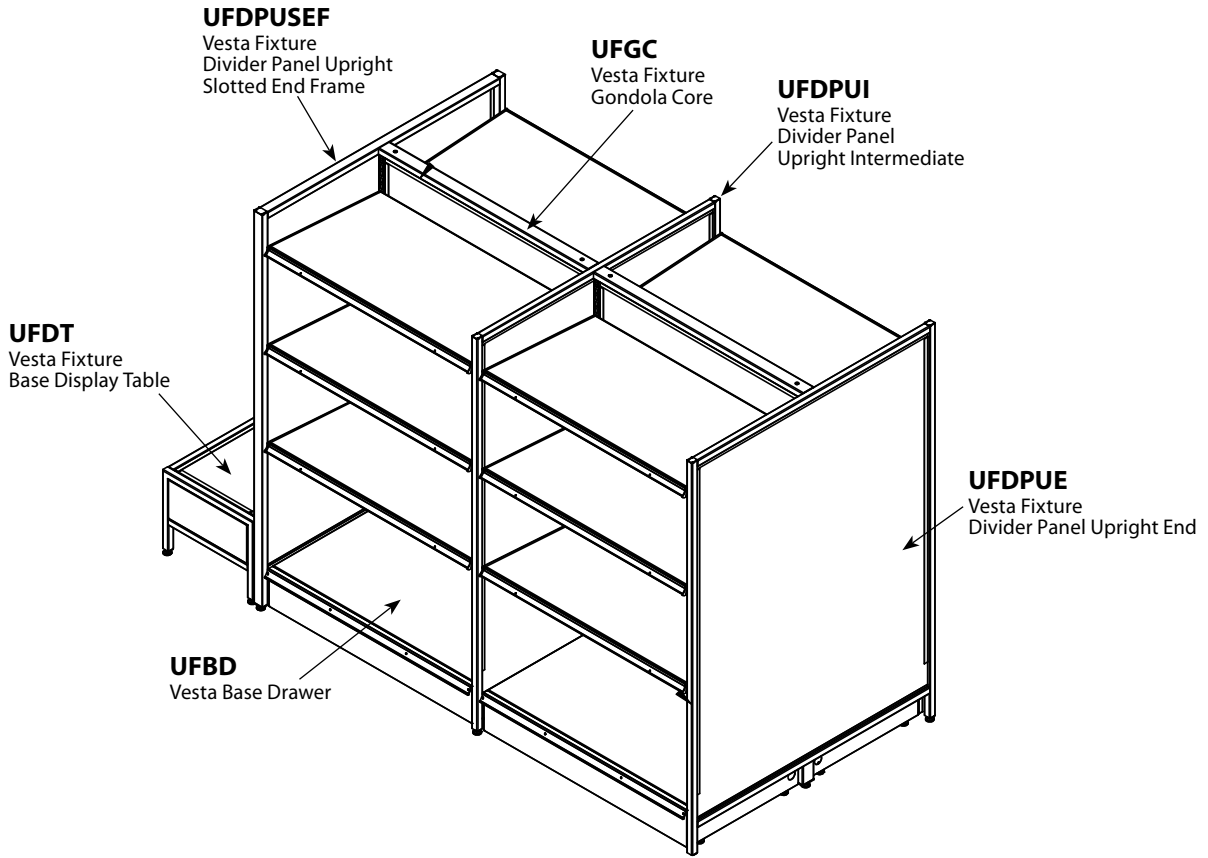

Use this Nominal Width Divider Panel for:						
Desired Shelf Depth	Wall	Double Sided Gondola	Slotted End Frame	Useable Depth		
UFUSA(OPT1)-(NW)(ND)(OPT1)	UFWDPU(OPT1)(NW)(NH)(OPT2)	UFDPU(OPT1)(NW)(NH)(OPT2)	UFDPUSEF(NW)(NH)(OPT)	ACTUAL	UFBD(NW)(ND)(NH)	UFDT(NW)(ND)(NH)(OPT1)(OPT2)
Nominal Shelf Depth	Wall Divider Panel	Gondola Divider Panel	Gondola Divider Panel	Available Depth	Drawer (Flushed to Front)	Base Table (Flushed to Front)
10"		24"		11.5"	N/A	11"
12"		30"		14.5"	14"	14"
14"		32"		15.5"	15"	15"
14"	20"			16.5"	16"	16"
16"		36"		17.5"	17"	17"
16"	22"			18.5"	18"	18"
18"		42"		20.5"	20"	20"
20"	26"			22.5"	22"	22"
20" or 22"				23.5"	23"	23"
22"	28"			2.5"	24"	24"
24"	30"			26.5"	26"	26"

### Vesta Fixture Gondola Core

- Slim profile 1" x 2" (25 mm x 51 mm) tubing upright
- Only two-tab Madix shelving may be used
- Easy installation

### UFGC(NW)(NH)(OPT1)(OPT2)

- UF.....Vesta Fixture  
 GC.....Gondola Core  
 NW.....Nominal Width  
 24", 30", 32", 36", 42", or 48"  
 (610 mm, 762 mm, 813 mm,  
 914 mm, 1067 mm, or 1219 mm)  
 NH.....Nominal Height  
 48", 54", 60", 66", 72", 84", or 90"  
 (1219 mm, 1372 mm, 1524 mm, 1676 mm,  
 1829 mm, 2134 mm, or 2286 mm)  
 OPT1.....Back Panel One  
 FA=Frosted Acrylic  
 MP=Milk Plex  
 HL=Hardboard  
 OPT2.....Back Panel Two  
 FA=Frosted Acrylic  
 MP=Milk Plex  
 HL=Hardboard  
 Z=No Back

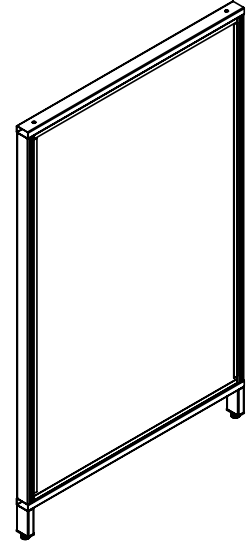

### Vesta Fixture Upright Divider Panel, End and Intermediate

- For use on a gondola when shelves are on both sides
- Only two-tab Madix shelving may be used
- Easy installation

### UFDP(U)(NW)(NH)(OPT2)

- UF.....Vesta Fixture  
 DPU.....Divider Panel Upright  
 OPT1.....E=End  
 I=Intermediate  
 NW.....Nominal Width  
 18", 24", 30", 36", 42", or 48"  
 (457 mm, 610 mm, 762 mm, 914 mm,  
 1067 mm, or 1219 mm)  
 NH.....Nominal Height  
 48", 54", 60", 66", 72", 84", or 90"  
 (1219 mm, 1372 mm, 1524 mm, 1676 mm,  
 1829 mm, 2134 mm, or 2286 mm)  
 OPT2.....Back Panel  
 FA=Frosted Acrylic  
 MP=Milk Plex  
 HL=Hardboard

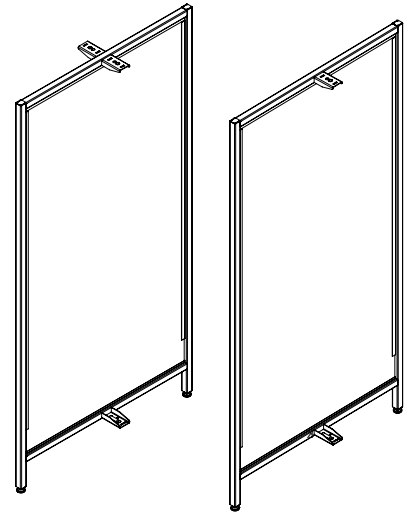

### Vesta Fixture Wall Divider Panel Upright End or Intermediate

- Slim profile 1" x 1" (25 mm x 25 mm) tubing
- Single panel design
- Easy installation
- Not slotted for shelves

### UFWDP(U)(NW)(NH)(OPT2)

- UF.....Vesta Fixture  
 WDP(U).....Wall Divider Panel Upright  
 OPT1.....L=Intermediate  
 L=Left Hand  
 R=Right Hand  
 NW.....Nominal Width  
 18", 20", 22", 24", 26", or 30"  
 (457 mm, 508 mm, 559 mm, 610 mm,  
 660 mm, or 762 mm)  
 NH.....Nominal Height  
 48", 54", 60", 66", 72", 84", or 90"  
 (1219 mm, 1372 mm, 1524 mm, 1676 mm,  
 1829 mm, 2134 mm, or 2286 mm)  
 OPT2.....Back Panel  
 FA=Frosted Acrylic  
 MP=Milk Plex  
 HL=Hardboard

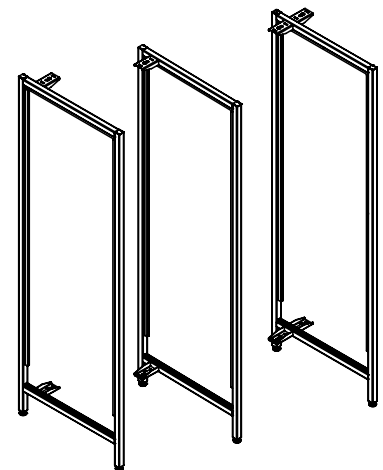

## Vesta Fixture Divider Panel Upright Slotted End Frame

- Slim profile 1" x 1½" (25 mm x 38 mm) tubing
- Only two-tab Madix shelving may be used
- Easy installation

### UFDPUSEF(NW)(NH)(OPT)

- UF.....Vesta Fixture
- DPU.....Divider Panel Upright
- SEF.....Slotted End Frame
- NW.....Nominal Width  
18", 24", 30", 36", 42", or 48"  
(457 mm, 610 mm, 762 mm, 914 mm, 1067 mm, or 1219 mm)
- NH.....Nominal Height  
48", 54", 60", 66", 72", 84", or 90"  
(1219 mm, 1372 mm, 1524 mm, 1676 mm, 1829 mm, 2134 mm, or 2286 mm)
- OPT.....Back Panel  
FA=Frosted Acrylic  
MP=Milk Plex  
HL=Hardboard

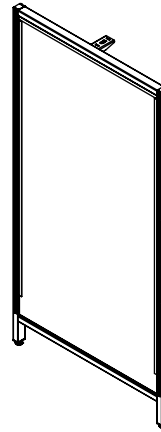

## Vesta Fixture Display Table

- Can be installed in the run or used as an end cap display
- Optional lighting makes product stand out
- Standard panels: Milk Plex

### UFDT(NW)(ND)(NH)(OPT1)(OPT2)

- UF.....Vesta Fixture
- DT.....Display Table
- NW.....Nominal Width  
24", 30", 32", 36", 42", or 48"  
(610 mm, 762 mm, 813 mm, 914 mm, 1067 mm, or 1219 mm)
- ND.....Nominal Depth 12", 14", or 16"  
(305 mm, 356 mm, or 406 mm)
- NH.....Nominal Height 12"  
(305 mm)
- OPT1.....Front Panel Option  
FA=Frosted Acrylic  
MP=Milk Plex  
HL=Hardboard Laminated Two Sides
- OPT2.....Top Panel Option  
FA=Frosted Acrylic  
MP=Milk Plex  
HL=Hardboard

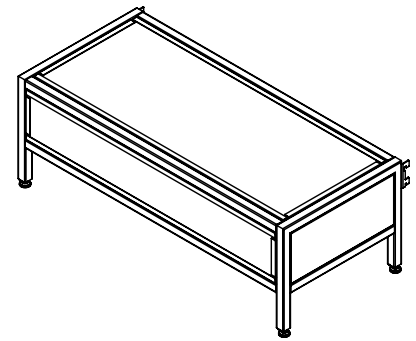

## Vesta Fixture Shelf

- Slim profile shelf maximizes merchandise space
- Includes standard 1¼" (32 mm) tag molding
- Standard Tops: Clear Acrylic, Frosted Acrylic, Milk Plex, Tempered Glass, Hardboard Laminated
- Other tops available, please contact your Sales Representative for more options
- Capacity load 100lbs per shelf

### UFUSA(OPT1)-(NW)(ND)(OPT1)

- UF.....Vesta Fixture
- USA.....Upper Shelf Assembly
- OPT1.....Light Option  
NL=No Light  
Blank=with Light
- NW.....Nominal Width  
18", 24", 30", 36", 42", or 48"  
(457 mm, 610 mm, 762 mm, 914 mm, 1067 mm, or 1219 mm)
- ND.....Nominal Depth 8" to 24" in 2" increments  
(203 mm to 610 mm in 51 mm increments)
- OPT1.....Top Option  
FA=Frosted Acrylic  
MP=Milk Plex  
HL=Hardboard Laminated 2 Sides  
TG=Tempered Glass  
CA=Clear Acrylic  
ND=None

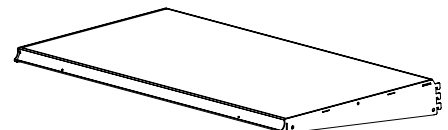

## Vesta Fixture Base Drawer

- Optimal base drawer with tag molding
- Allows storage of inventory on sales floor
- Ball bearing slides allow easy operation

### UFBD(NW)(ND)(NH)

UF.....Vesta Fixture  
 BD.....Base Drawer  
 NW.....Nominal Width 24", 36", 42", or 48"  
 (610 mm, 914 mm, 1067 mm, or 1219 mm)  
 ND.....Nominal Depth 14" to 26"  
 (356 mm to 660 mm)  
 NH.....Nominal Height  
 06" or 08" (152 mm or 203 mm)

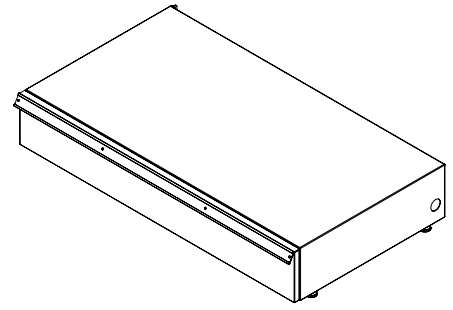

## Lighted Upper Shelf Assembly

- Shelf assembly includes Slimline Light Fixture Kit (SLFK) affixed to standard brackets to fit Maxi
- Several sizes, finishes, and top surfaces are available
- Shelf lights ship installed to fixture
- Shelf lights ship installed to fixture
- Order one Slimline Light Fixture Power Cord (SLFPC) for each run and one Slimline Light Fixture Connector Cord (SLFCC) for each Lighted Upper Shelf added to a run
- Maximum of 36' (10,972 mm) daisy-chained to one another [nine 4' (1219 mm) fixtures]
- 20 amp circuit will handle up to twenty-seven 4' (1219 mm) fixtures with 28 watt T5 bulbs (maximum on 3 strings of 9 fixtures)
- Load capacity 100 lbs for each shelf

### LUSA-(NW)(ND)-(OPT)

LUSA.....Lighted Upper Shelf Assembly  
 NW.....Nominal Width 3', 4'  
 (914 mm, 1219 mm)  
 ND.....Nominal Depth  
 12", 14", 16", 18", 20", 22", or 24"  
 (305 mm, 356 mm, 406 mm, 457 mm,  
 508 mm, 559 mm, or 610 mm)  
 OPT.....Top Option  
 TG = Tempered Glass  
 CA = Clear Acrylic  
 FA = Frosted Acrylic  
 ND = No Deck

Bottom View

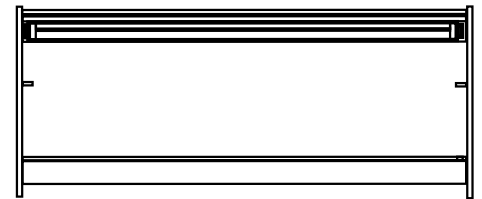

Top View

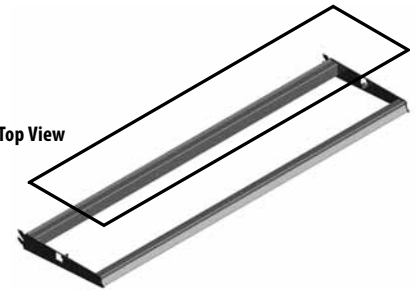

## Vesta Fixture Gondola Core Sign Holder Stems

- Sits on top of the core
- Customer supplies sign and any sign holder

### UFGCSHS04

VFG.....Vesta Fixture Gondola  
 CSH.....Core Sign Holder Stems  
 04.....Nominal Height 04"  
 (102 mm)

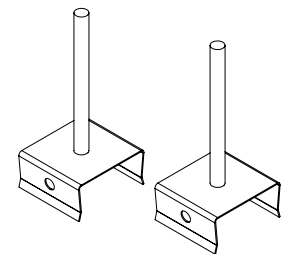

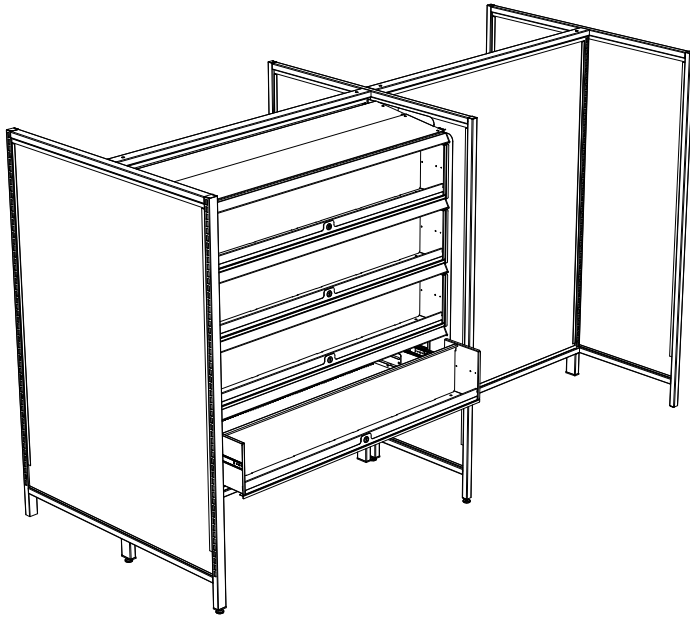

## Tube Line Metal Shelf

- Flush front shelf with diamond perforations

### TLMS(OPT1)(NW)(ND)

- TLMS.....Tube Line Metal Shelf
- OPT1.....D=Diamond Perferated  
NP=Non-Perferated
- NW.....Nominal Width  
18", 24", 30", 36", 42", or 48"  
(457 mm, 610 mm, 762 mm, 914 mm,  
1067 mm, or 1219 mm)
- ND.....Nominal Depth 08" to 24" in 2" increments  
(203 mm to 610 mm in 51 mm)

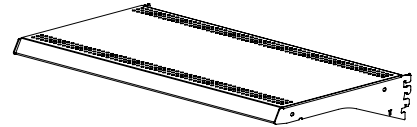

## Tube Line Pull-Out Demo Display

- Requires the use of Tube Line Metal Shelf at top and bottom of each display

### TLUPODD(NW)1016(OPT)

- TL.....Tube Line
- UPODD.....Universal Pull-Out Demo Display
- NW.....Nominal Width  
36" or 48" (914 mm or 1219 mm)
- 1016.....Nominal Depth 10" to 16" range pull-out  
(254 mm to 406 mm range pull-out)
- OPT.....KL=Kenstan Lock  
Blank=Standard Lock

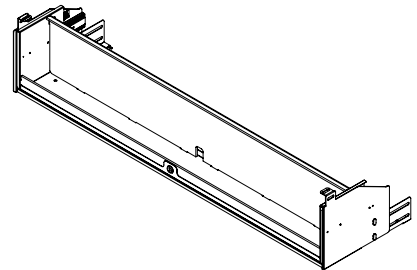

## Tube Line Universal Pull-Out Demo Display End Panel

- Nominal Height must be in 10" increments  
20" covers two pull-outs  
40" covers four pull-outs

### TLUPODDEP(NH)1016(OPT)

- TL.....Tube Line
- UPODD.....Universal Pull-Out Demo Display
- EP.....End Panel
- NH.....Nominal Width  
20" or 40" (508 mm or 1016 mm)
- 1016.....Nominal Depth 10" to 16" range pull-out  
(254 mm to 406 mm range pull-out)
- OPT.....LH=Left Hand  
RH=Right Hand

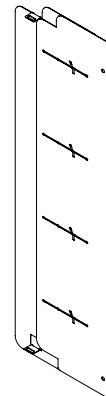



### LEDge Light

LEDge Light is the first LED lighting product designed specifically for use on display shelves. Environmentally friendly LEDs produce light intensity similar to T5 fluorescent fixtures, while using only half the energy and lasting nearly three times as long without replacement or maintenance. LEDge Light produces virtually no heat, no UV rays (eliminating packaging degradation) and features a specially designed lens for optimal light distribution. Optional dimming controller with infrared sensors may reduce energy consumption by over 50% and double the life of the fixture.

- 2', 3', and 4' lengths (610 mm, 914 mm, or 1219 mm)
- Maintenance-free life in excess of 50,000 hours (11 years at 12 hours/day)
- Compact, 1.18" x .88" (30 mm x 22 mm) profile
- Durable aluminum extrusion
- Integral magnets make installation on metal shelves or other surfaces easy and allow fast changes
- End tabs with holes for fastening to wood shelves, counters, or other surfaces
- UL listed system
- Energy Star certified
- All plug 'n play connections– no electrician required (class 2 system)
- Multiple units connected using Jumper Cables or Harness Assembly
- May be daisy-chained to single power supply for "single row" applications
- Power up to ten 48" LEDge Lights with one power supply (see chart)
- Color temperature: 4200K
- Color Rendering Index (CRI) of 85
- Contains no heavy metals
- Low power consumption helps meet California Title 24 lighting regulations
- Safe 24 volt DC system
- 2-year warranty
- Not compatible with Lumiback or Lumishelf™ accessories

#### LLS(NL)

LLS .... LEDge Light  
 NL .... Nominal Length 24", 36", or 48"  
 (610 mm, 914 mm, or 1219 mm)

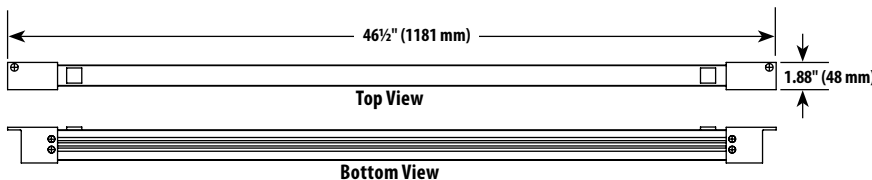

Shelf Width	Part Number	Actual Length	DC Watts	Max # Lights per Power Supply
24"	LLS24	22½"	4.8W	20
36"	LLS36	34½"	7.2W	13
48"	LLS48	46½"	9.6W	10



## LEDge Light Harness Assembly

- Harness Assembly is used to connect up to 6 LEDge Lights to a single 100W power supply
- Up to 12 lights may be connected to a single Harness Assembly by using 2 power supplies
- Harness plugs directly into power supply
- Jumper Cables required to connect LEDge Lights to Harness Assembly
- 6 modules, 12.25" (311 mm) OC with 72" (1829 mm) leads for each power supply connection
- Screw tab on each connecting module allows fastening to perforated back panel via push rivets or to other surfaces with screws (not included)
- White color

### LLHA

LLHA.....LEDge Light Harness Assembly

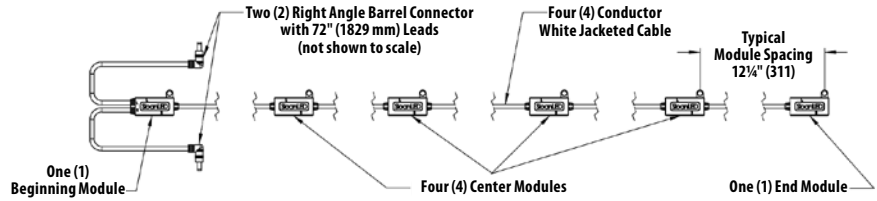

## LEDge Light Jumper Cable

- Required to connect LEDge Lights to Harness Assembly and adjacent lights in daisy-chain applications
- White color

### LLJ(NL)

LLJ.....LEDge Light Jumper Cable  
 NL.....Nominal Length 6", 18", 30", 72", 144"  
 (152 mm, 457 mm, 762 mm, 1829 mm, 3658 mm)

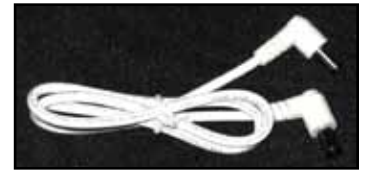

## LEDge Light Power Supply

- UL Listed 100W power supply features nearly 90% efficiency through use of latest circuitry design
- 120V standard plug– no electrician required
- Maximum of 16 power supplies per 20 amp circuit
- Not compatible with Lumi-M-Stick, Lumiback, or Lumishelf™

### LLPS

LLPS.....LEDge Light Power Supply



## LEDge Light Cable Clamp

- Use to cleanly route cables
- Clear nylon with adhesive back
- 3/8" (10 mm) capacity
- 25 pieces per pack

### LLCC38-25

LLCC.....LEDge Light Cable Clamp  
 38 .....3/8" (10 mm) capacity  
 25 .....25 pieces





## ILLUMINATE MERCHANDISE AT THE POINT OF SALE

LEDge Light Versa is Madix's most versatile lighting solution for retail shelves. It features LED lights that draw attention to merchandise, which boosts sales. LEDge Light Versa's connectors allow retailers to quickly and easily reset shelves without the hassle of unplugging and reconnecting the lights' wires. Simply unhook and reattach the shelves to the uprights, lining up the Versa's Connectors to the Bus Bars on the backboards. The lights will automatically illuminate.

- Engineered to install on most metal shelving systems
- Quickly reset plan-o-grams without moving wires
- Cut the expense of hiring electricians
- Reduce the cost of store associates' labor

## HOW VERSA WORKS

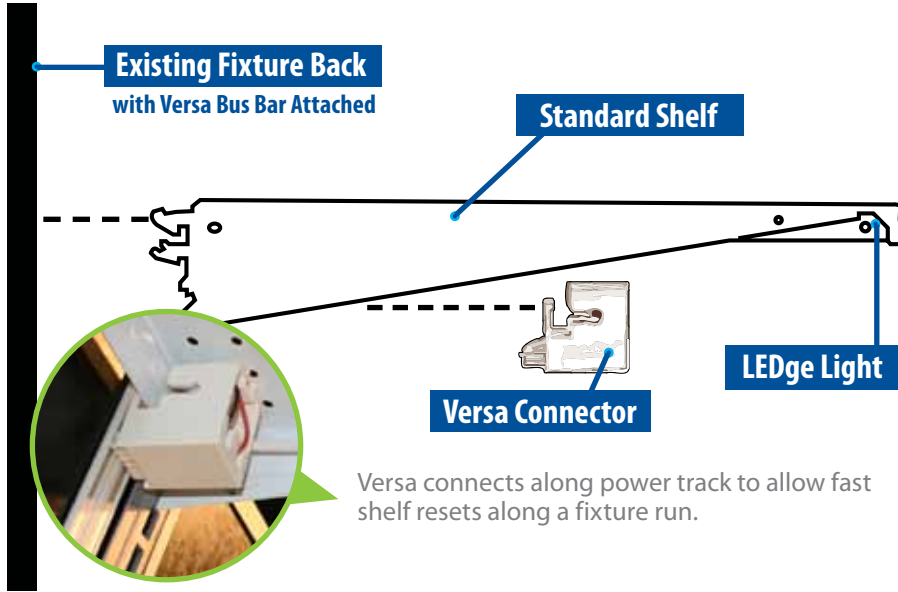

### LEDge Light Versa Connector

- Complete assembly includes connector and cable
- Versa connector needs to be size of shelf or deeper

### LLVC(ND)

LLVC.....LEDge Light Versa Connector  
 ND.....Nominal Depth  
 12", 18", 30" (305 mm, 457 mm, 762 mm)



### LEDge Light Versa Bus Bar

- Fits 54" (1372 mm) back panels, can be mounted on larger panels in higher position
- Can be trimmed to fit shorter panels

### LLBB(NL)

LLBB.....LEDge Light Versa Bus Bar  
 NL.....Nominal Length 46" (1168 mm)



### LEDge Light Versa Y-Connector

- Splitting connecting LEDge Light Versa Bus Bars to power supply
- 15" (381 mm) overall length

### LLVY

LLVY .....LEDge Light Versa Y-Connector

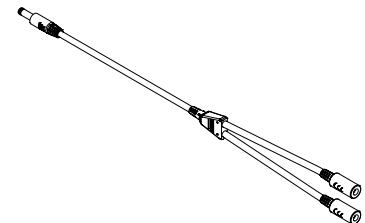

## LEDge Light Dimming Controller Kits

Dimming controllers use infrared sensors to dim or shut off LEDge Lights when customers are not shopping the aisle. Dimming is adjustable from off to 12%, 25%, or 50% of total intensity. State-of-the-art control dims and ramps up light slowly, making the change less noticeable to customers. Use of dimming control may cut energy consumption by over 50% and double life of LEDge Light.

### LEDge Light Dimming Controller Starter Kit

- Controls single 100W power supply
- Kit contains one dimming controller, two infrared sensors, cables and connectors for use in up to a 24' (7315 mm) run (longer runs require Sensor Add-On Kit– see below)
- Sensor detection range is 14' (4267 mm) diameter
- Specify sensor mounts for slotted upright (B) or shelf (S)
- Plug and play connections– no electrician required
- White color
- Not compatible with Lumi-M-Stick, Lumiback, or Lumishelf™

### LLDCS-(TYPE)

LLDCS.....LEDge Light Dimming Controller Starter Kit  
 TYPE.....Sensor Mount Type:  
 B=Slotted Upright  
 S=Shelf

### LEDge Light Dimming Controller Add-On Kit

- Order this kit to control additional power supplies (one kit per power supply)
- Contains one dimming controller, cables and connectors to add one power supply
- Plug and play connections– no electrician required
- White color
- Not compatible with Lumi-M-Stick, Lumiback, or Lumishelf™

### LLDCA

LLDCA.....LEDge Light Dimming Controller Add-On Kit

### LEDge Light Motion Sensor Add-On Kit

- Order this kit where additional sensors are required in system [at center of any run that exceeds 24' (7315 mm)]
- Kit adds a single sensor to Starter Kit above
- Contains one infrared sensor, cables and connectors to add 12' (3648 mm) to run
- Specify sensor mounts for slotted upright (B) or shelf (S)
- Plug 'n play connections– no electrician required
- White color
- Not compatible with Lumi-M-Stick, Lumiback, or Lumishelf™

### LLMSA-(TYPE)

LLMSA.....LEDge Light Motion Sensor Add-On Kit  
 TYPE.....Sensor Mount Type:  
 B=Slotted Upright  
 S=Shelf

## LEDge Light Dimming Components

Individual components to be used with Starter and Add-On Kits as needed.

### LEDge Light Dimming Controller

#### LLDC

LLDC.....LEDge Light Dimming Controller

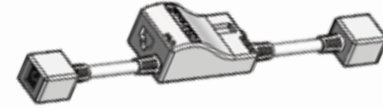

### LEDge Light Motion Sensor

• 60" (1524 mm) cord

#### LLMS

LLMS.....LEDge Light Motion Sensor



### LEDge Light Sensor Mounting Bracket

• Specify sensor mounts for slotted upright (B) or shelf (S)

#### LLSMB-(TYPE)

LLSMB.....LEDge Light Sensor Mounting Bracket

TYPE.....Sensor Mount Type:  
B=Slotted Upright  
S=Shelf

### LEDge Light Cat 5 Cable

• Used to connect Motion Sensor to Dimming Controller

#### LLC5C-(NL)

LLC5C .... LEDge Light Cat 5 Cable

NL .... Nominal Length 3', 15', 25', 50'  
(914 mm, 4572 mm, 7620 mm, 15,240 mm)



### LEDge Light Cat 5 Coupler

#### LLC5CP

LLC5CP .... LEDge Light Cat 5 Coupler



### LEDge Light Cat 5 Y-Splitter

#### LLC5YS

LLC5YS .... LEDge Light Cat 5 Y-Splitter



## Terms and Conditions

### Prices

All prices are subject to change without notice. Every effort will be made to give advance notice of any increase through notification from the home office. The customer will receive an acknowledgement showing prevailing prices at the time the order is processed. State or other sales or use taxes, freight and surcharges will be charged when applicable. Freight quotes may be provided based upon information available at time of quote, but are not guaranteed. Active freight charges will be billed if applicable. When market conditions dictate, a surcharge may be implemented. All quotations automatically expire at the end of 30 days.

### Terms

Cash in advance prior to production or net 30 days if open account status is approved by Madix Credit Department. MasterCard, Visa, and American Express are accepted.

### Acceptance

All orders, contracts, and agreements are subject to Madix's acceptance and approval. Madix shall not be liable for any delay in the performance of any order, contract, in the delivery of any goods, or for any damages resulting from such delay, when such delay is directly or indirectly caused by or due to fire, flood, accident, riot, act of God, war, governmental decree or order, strike, labor difficulties, shortage of labor, fuel, power, material or supplies, transportation delay or any other delay or causes (whether or not similar to any of those herein before specified) beyond our reasonable control. Order acceptance will be per the conditions and terms outlined in Madix's acknowledgement. Mailing of the acknowledgement will signify Madix's acceptance of the order.

### Minimum Charge

All orders less than \$50.00 net (merchandise only) will be invoiced at \$50.00.

### Charges and Cancellations

Customer requested changes and cancellations are subject to approval by Madix. Every reasonable effort will be made to accommodate these requests without additional cost to the customer. Any manufacturing or engineering costs incurred will be charged to the customer. Orders produced and delayed for more than one week may incur charges for demurrage, unloading, or other storage costs. Madix will advise customers of the estimated charges at the time changes or cancellations are made.

### Shipments

Method and route of shipment are at Madix's discretion unless Madix is furnished with complete shipping instructions at least ten (10) days before the scheduled shipping date. Freight is FOB/EXW Madix shipping point.

### Freight Claims

For common carrier shipments, claims must be made directly with the carrier by the recipient. Listed are the types of losses which may occur, and your responsibility in handling them:

**Loss of Freight:** It is the receiver's responsibility to count the freight at the time of delivery. Any exception must be noted on the carrier's delivery receipt at time of delivery.

**Damage of Freight:** As with a loss of freight, damage of freight must be noted on the carrier's delivery receipt at the time of delivery. It is the receiver's responsibility to make sure that the freight is inspected for visible damage and that the number of pieces damaged is marked on the carrier's delivery receipt. Failure to note visible damage at the time of delivery will result in non-payment of a damage freight claim. Salvage must be held for the carrier.

**Concealed Damage:** If goods are received in apparently good condition but there is concealed damage, it is the customer's responsibility to contact your Madix Service Representative within 15 calendar days from delivery. Customer must keep the product and the packaging so that an inspection may be conducted by the carrier. Failure to handle a concealed damage claim in this manner could greatly reduce the amount recovered from the carrier.

### Returned Goods

Returned Goods requests must be submitted to Madix, Inc. within 60 days after receipt of product. Authorization must be in writing on Madix's RGA (Return Goods Authorization) form. Goods must be received within 30 days of RGA issue date for credit. Only Code A products finished in returnable colors as indicated on the finish policy pages will be considered for return, and only items in unused, in resalable condition, and in the original packaging. No special size, color, or specially manufactured parts or products are eligible for return unless sent to the customer as the result of an error by Madix. Only merchandise listed on the RGA will be accepted for conditional return. Credit will not be issued for that portion of merchandise that is not considered resalable. A handling and restocking charge of 25% of the invoice price will be charged for all approved returns. Submit requests to your Madix Sales Representative or Customer Service Department prior to returning any merchandise. All returns must have the customer name and Madix RGA number prominently displayed on each package. Product to be shipped prepaid at customer's expense unless prior approval has been received from an authorized Madix Representative.

### Warranty

We warrant to the original purchaser that all products manufactured by Madix are free from defects in material and workmanship. This warranty is invalid if products or parts are modified or used in a manner other than the intended purpose. Our obligation under this warranty is limited to repairing or replacing of any part or parts which shall, within one (1) year after delivery to the original purchaser, be demonstrated to be defective under normal use and service. This warranty is in lieu of all other warranties, expressed or implied, and of all other obligations or liabilities of any kind on Madix's part, and no modification of this warranty shall be valid or binding unless in writing and signed by an officer of Madix, Inc.

**POSSESSION OF THIS CATALOG IS NOT AUTHORIZATION TO SELL MADIX PRODUCTS!  
ALL FACTORY QUOTES ARE GOOD FOR 30 DAYS ONLY.**

## Product Information

### Production

Madix fixtures are manufactured utilizing the most current technology of highly automated systems with process control techniques. Skilled craftsmanship, combined with automatic presses, roll forming machines, multi-spot welders, conveyers, finishing equipment and thorough inspections produce store fixtures of the highest quality.

### Upright

Carefully engineered of heavy gauge, high quality steel components, the UPRIGHT is slotted one inch on center for maximum flexibility, shelf adjustability and use of available space. Standard heights range from 36" through 96" with built-in leveler. For the finishing touch at the end of the shelving run, the snap-on UPRIGHT END COVER is made of durable, scuff and impact resistant plastic or heavy gauge metal. The UPRIGHT CAP, made of high impact plastic, has provision for a sign holder.

### Base Shoe

The five inch low BASE SHOE features exclusive "I" beam design, engineered of projection welded high strength steel parts insuring maximum load capacity. Snaps securely into upright with leveler and electrical access allowing for quick error free installation. For the finished look, the one piece slip on BASE END COVER is made with a high impact plastic nose reinforcement to protect base shelf tag molding.

### Spanners

Snap-in support SPANNERS keep uprights at equal spacing and hold the back panels rigid. Each spanner has knockouts for electrical access and telescoping uprights.

### Back Panels

High density hardboard BACKS fit flush to the face of the upright. A wide variety of finishes include solid, pegboard, wood grain and fabric in a wide assortment of optional colors. Mirrors and open backs are also available.

### Kickplate

Fully floating feature of kickplate allows flush fit against uneven floors, snaps in and out without disturbing base shelf for easy cleaning. Convenient knockout accommodates electrical access.

### Base and Upper Shelves

Steel base shelves feature lock tabs to insure quick installation and precision alignment. A double row of 1/4" inch perforations on the front and rear edge makes any form for binning possible. Slim bracket, high tensile design with flat or 15 degree downslope upper shelf positions allow for maximum merchandise visibility. Integrally formed price tag molding accommodates 11/4" tag. Upper shelves available in 8", 10", 12", 14", 16", 20", 22", 24", 26", 28", and 30" depths. Base shelves available in 12", 14", 16", 18", 20", 22" 24", 26", 28", and 30" depths.

### Shelf Loading

The recommended load capacity for upper shelves is based on evenly distributed weight. Capacities are reduced by 35% when front half is loaded and reflect rated maximum load. Load capacities are shown in the General Information Section under Shelf Loading.

### Baked Enamel, Powder Coat Finishes

All metal parts are finished with a specially formulated high solids or powder which are electrostatically bonded in a unique multi-stage process, to insure the highest quality finish. Aerosol cans of Touch-up paint are available in Madix's standard and optional colors. FAA regulations prohibit the shipment of this product by air or in export containers by air or ocean to countries outside the United States.

### Product Maintenance

When necessary to clean Madix shelving, use a non-abrasive mild detergent and warm water, followed by thorough drying. The use of a cloth made of a soft white cotton material is strongly recommended. The use of cleaning products that contain abrasive, bleach, or strong solvents, such as ketones, ethers, etc. will result in damage to the finish. The damage is most severe when these harsh cleaning agents are used on colors which contain leafing aluminum pigment such as powder chrome, silver vein, and other "vein" type finishes. The aluminum in these coatings resides at the surface of the finish and is therefore susceptible to damage by the harsh cleaning agents. As an alternative to the mild detergent, cleaners with ingredients similar to those found in products such as 409, Fantastik, and Simple Green can be used. Caution! Cleaners having ingredients similar to those found in Ajax, Borax, Comet, etc. should be avoided as finish damage could result.



## Shelving Safety

### Codes

In your planning stage, consult with local municipal engineers to determine what codes and restrictions will be applicable in the locations where the shelving will be used. Codes may include: state, local, fire, building, and health and safety codes. Seismic requirements may apply in some locations. For example, in most locations fire codes state that fixtures need to be at least 18 inches below the sprinklers.

### Shelving Selection

Take into consideration the load that is expected not only on each shelf but also on the unit as a whole. Take into account the upright capacity. Refer to the load capacity information that is in the Madix Standard Catalog. Madix shelves are rated using an evenly distributed load. Do not install shelves or accessories that extend beyond the depth of the Base Shelves. Consider making the Base Shelves and low height fixtures a contrasting color from the floor's color to prevent potential tripping hazards. Do not use Madix parts or accessories for any purpose other than originally intended by Madix.

### Shelving Installation

Initial installation or relocation of Madix shelving should be supervised by qualified personnel. Madix products should be installed according to Madix's specifications. Madix's installation sequence must be followed for assembly and leveling. An improperly installed store fixture has a poor appearance and may cause a dangerous condition. Be especially careful when leveling fixtures with offset loads in which one side of the fixture has a considerably heavier load than the other side. Dismantling and reassembling used Madix shelving can be dangerous if the installers who are doing the work leave out parts, use damaged parts, or do not reassemble the product by Madix's specifications. Do not alter, modify, or structurally change any shelving component. Do not move assembled shelving. Only parts and accessories that are produced and supplied by Madix are covered by the Madix warranty. Do not assemble Madix fixtures with parts from other manufacturers. Under no circumstances should you use damaged parts. When assembling Gondola/Wall Shelving, install Kickplates to protect the Base Shoes from floor cleaning equipment and to offset the possible bumping and misalignment of the shelving runs. Do not install shelves or accessories on the sides of wall sections or any section that is not supported by Base Shoes. Use caution when handling and transporting shelving parts. Be careful when cutting shrink wrap from pallets because the shelving parts can dislodge from the wrap and fall. Cut the wrap gradually from the top, only as much as you need to remove the product from the top. Two common hazards while installing store fixtures are: employees hurting themselves with improper types of box cutters and employees putting boxes on the floor and then tripping over them.

### Anchoring and Floors

Depending on code requirements and Madix's specifications, some products must be anchored to the walls and/or floors. Do not lean tall or heavy objects against unanchored shelving systems. Retailers must consider the type of floor upon which the shelving will be installed.

### Impact Loading

Impact during the loading and unloading of merchandise can create an adverse loading situation and may result in damage to or failure of the Madix shelving. Do not walk or climb on Madix shelving.

### Overturning

Overloading the top portion of the shelving, non-uniform loading, out-of-plumb installation, and impact can cause shelving to overturn. Improperly installed Madix shelving with offset loads can cause store fixtures to collapse. Carefully follow Madix's installation instructions in order to prevent shelving from overturning.

### Additional Shelving Safety Pointers

Product loading instructions are included with each Madix order. Retailers must make merchandisers aware of the product's load limitations and the dangers of overloading the shelving. Remove any merchandise or overstock before attempting to move Madix shelving. Periodically inspect your Madix shelving for damaged or loose parts. Make sure that shelves and accessories are properly seated in the slotting or perforations. Make sure that shelves and accessories are not overloaded. As merchandising changes, beware of creating offset loads on shelving runs that are not properly leveled. Look for leveling warning signs such as increased gaps between shelves or accessories that may indicate that the shelving runs need re-leveling. Damage to Madix shelving is dangerous. In some cases, the shelving should be unloaded immediately and repaired or replaced before returning to service. Re-level fixtures that you have bumped or moved. Incorporate safety into your merchandising strategy. When possible, merchandise the heavier products on the lower shelves. If the merchandise will not fit on the Madix shelves and there is a replenishment cycle, make sure that the cycle is a safe one. Make sure that merchandise and overstock are properly stacked and maintained so that items will not fall into the aisles. Assure that customers who handle merchandise or overstock will not push product from one side of the Madix fixture to the other side where people could be injured from falling merchandise. Safely secure overstock that is placed on Madix shelves overhead. Measure the difficulty that your employees have in retrieving overstock, and consider whether employees or customers could be injured if the product happens to fall from the shelving units. Teach employees and inform customers that Madix shelves should never be used as ladders to reach higher shelves. Ladders should be clearly marked for employees use only and should not be left unattended, or customers will try to remove stock on higher shelves by themselves. Notify customers to ask for assistance when they need product that is out of their reach.

## Finish Policy for Metal Products

### Standard Colors, Returnable– Code A

Madix standard returnable colors for display shelving are Sahara, Blue Gray, Oyster, Snow White, and Satin Black. Madix standard returnable colors for wire products only are Powder Chrome and Silver Vein. All catalog items are priced in standard color.

### No Charge Colors (Non-Returnable)– Code B

Madix non-returnable colors offered at the standard price are Chocolate, Dove Gray, Dover White, Fashion Gray, Skyline Gray and Tru Gray. All catalog items are priced in standard color.

### Optional Colors-Level I Finishes (Non-Returnable)– Code B

Madix offers optional colors, also known as Grade I Finishes, at additional charge: Bright Orange, Hollyberry, Hunter Green, Mandarin, Neon Blue, Spectrum Blue, Spectrum Green, Spectrum Red and Valencia. Products painted with these colors are non-returnable.

**Metal Components:** \$350.00 line charge plus published per-piece charge.

**Metal Back panels:** \$350.00 line charge plus published per-piece charge.

### Special Colors– Code C

Use line change charge plus per piece charge supplied by customer service. Special colors are non-returnable.

### Pricing For Levels II To IV:

**Level II:** 1.6 x Optional Color Upcharge. Example: Optional upcharge for SUS is \$1.50; upcharge with Level II finish will be \$2.40.

**Level III:** 2.8 x Optional Color Upcharge. Example: Optional upcharge for SUS is \$1.50; upcharge with Level III finish will be \$4.20.

**Level IV:** 3.8 x Optional Color Upcharge. Example: Optional upcharge for SUS is \$1.50; upcharge with Level IV finish will be \$5.70.

**Metal Components:** \$500.00 line charge plus published per-piece charge.

**Back panels:** \$350.00 line charge plus published per-piece charge.

## Maintenance for Metal Products

### Baked Enamel and Powder Coated Finishes

All metal parts are finished with a specially formulated high solids or powder which are electrostatically bonded in a unique multi-stage process to insure the highest quality finish. Aerosol cans of touch-up paint are available in Madix's standard and optional colors. FAA regulations prohibit the shipment of this product by air or in export containers by air or ocean to countries outside the United States.

### Product Maintenance

When cleaning Madix shelving, use a non-abrasive mild detergent and warm water, followed by thorough drying. Using a soft white cotton cloth is strongly recommended. Cleaning products containing abrasives, bleach, or strong solvents will result in damage to the finish, especially when used on colors containing leafing aluminum pigment, such as powder chrome or vein-type finishes.

## Finish Policy for Wood Products

### High Pressure Laminate

The terms "laminate" or "HPL" are commonly applied to this material which consists of multiple layers of paper infused with phenolic resin and topped by a finish paper coated with clear melamine resin, all totally bonded under high pressure and heat. The finished sheet has extremely high wear and impact resistance.

### Customer Specified High Pressure Laminate

Madix coding is based on Wilsonart availability. Laminates other than Wilsonart may require additional lead time.

- Customer specified laminates add \$100.00 per pattern, per order
- Additional charge will apply based on the laminate grade that is chosen

Laminates that are not from a laminate manufacturer's standard samples (metallics, heavy textures, wet looks, core edge, special prints) will require a special quote. Contact Customer Service for specific pricing on laminates not listed above.

### Thermofused Panels

Thermofused panels are ideal for non-wear surfaces and have substantial impact and wear characteristics compared to melamine panels previously available. The product is produced using hot press laminating polyester or melamine resin impregnated self-bonding paper to wood substrate. Performance specifications are available from the American Laminations Association. Madix does not recommend the use of Thermofused panels on horizontal or other wear surfaces.

### Printed Mirror Hardboard

Printed materials are primarily used for back panels, but appear as various other products. These materials are carefully cross matched to the corresponding laminates and Thermofused. Mylar mirror hardboard is used in the same applications and is also available in pegboard and grooved pegboard.

### NOTE!

See Finishes Brochure for color samples

## Finish Policy for Back Panels

### Standard Colors, Returnable– Code A

Madix standard returnable colors for display shelving back panels are Sahara, Oyster, and Snow White.

### Optional Colors-Level I Finishes (Non-Returnable)– Code B

Madix non-returnable back panel colors offered at the optional price are Chocolate, Dove Gray, Dover White, Fashion Gray, Satin Black, Skyline Gray, Blue Gray and Tru Gray. Set-up charge of \$350.00 applies.

### Optional Colors-Level II Finishes (Non-Brilliant)– Code B

Madix offers optional back panel colors also known as non-brilliant finishes at an additional charge. These colors include custom grays, off whites, tans, and beiges not listed in Madix's Finishes brochure. Products painted with these colors are non-returnable. Set-up charge of \$350.00 applies.

### Optional Colors-Level III Finishes (Brilliant)– Code C

Brilliant back panel finishes include Hunter Green, Neon Blue, Spectrum Blue, and Spectrum Green. Set-up charge of \$350.00 applies.

### Optional Colors-Level IV Finishes (Reds and Yellows)– Code C

Use line change charge plus per piece charge supplied by customer service. Special colors are non-returnable. Set-up charge of \$350.00 applies.

## Pricing For Levels II To IV

### Level II

1.2 x the difference between the Hardboard/Pegboard Optional Color pricing and the Hardboard/Pegboard Sahara pricing.

**Example:** Optional upcharge for a BH-342 with a Level II finish would be calculated as follows:

$\$13.85 - \$12.45 = \$1.40 \times 1.2 = \$1.68$ . The color upcharge for a BH-342 with a Level II finish is \$1.68. This upcharge amount will be added to the Optional Color price of a BH-342. The new price of a BH-342 using a Level II finish is \$15.53 ( $\$13.85 + \$1.68 = \$15.53$ ).

### Level III

1.4 x the difference between the Hardboard/Pegboard Optional Color pricing and the Hardboard/Pegboard Sahara pricing.

**Example:** Optional upcharge for a BH-342 with a Level III finish would be calculated as follows:

$\$13.85 - \$12.45 = \$1.40 \times 1.4 = \$1.96$ . The new color upcharge for a BH-342 with a Level III finish is \$1.96. This upcharge amount will be added to the Optional Color price of a BH-342. The new price of a BH-342 using a Level III finish is \$15.81 ( $\$13.85 + \$1.96 = \$15.81$ ).

### Level IV

1.8 x the difference between the Hardboard/Pegboard Optional Color pricing and the Hardboard/Pegboard Sahara pricing.

**Example:** Optional upcharge for a BH-342 with a Level IV finish would be calculated as follows:

$\$13.85 - \$12.45 = \$1.40 \times 1.8 = \$2.52$ . The color upcharge for a BH-342 with a Level IV finish is \$2.52. This upcharge amount will be added to the Optional Color price of a BH-342. The new price of a BH-342 using a Level IV finish is \$16.37 ( $\$13.85 + \$2.52 = \$16.37$ ).

## NOTE!

See Finishes Brochure for color samples

Part Name	Part Number	Page Number
<b>L</b>		
LEDge Light.....	LLS(NL).....	9
LEDge Light Cable Clamp.....	LLCC38-25.....	10
LEDge Light Cat 5 Cable.....	LLC5C(NL).....	14
LEDge Light Cat 5 Coupler.....	LLC5CP.....	14
LEDge Light Cat 5 Y-Splitter.....	LLC5SYS.....	14
LEDge Light Dimming Controller.....	LLDC.....	14
LEDge Light Dimming Controller Add-On Kit.....	LLDCA.....	13
LEDge Light Dimming Controller Starter Kit.....	LLDCS-(TYPE).....	13
LEDge Light Harness Assembly.....	LLHA.....	10
LEDge Light Jumper Cable.....	LLJ(NL).....	10
LEDge Light Motion Sensor.....	LLMS.....	14
LEDge Light Motion Sensor Add-On Kit.....	LLMSA-(TYPE).....	13
LEDge Light Power Supply.....	LLPS.....	10
LEDge Light Sensor Mounting Bracket.....	LLSMB-(TYPE).....	14
LEDge Light Versa Bus Bar.....	LLBB(NL).....	12
LEDge Light Versa Connector.....	LLVC(ND).....	12
LEDge Light Versa Y-Connector.....	LLVY.....	12
Lighted Upper Shelf Assembly.....	LUSA-(NW)(ND)-(OPT).....	7

Part Name	Part Number	Page Number
<b>T</b>		
Tube Line Metal Shelf.....	TLMS(OPT1)(NW)(ND).....	8
Tube Line Pull-Out Demo Display.....	TLUPODD(NW)1016(OPT).....	8
Tube Line Universal Pull-Out Demo Display End Panel.....	TLUPODDEP(NH)1016(OPT).....	8

Part Name	Part Number	Page Number
<b>V</b>		
Vesta Fixture Base Drawer.....	UFBD(NW)(ND)(NH).....	7
Vesta Fixture Display Table.....	UFDT(NW)(ND)(NH)(OPT1)(OPT2).....	6
Vesta Fixture Gondola Core Sign Holder Stems.....	UFGCSHS04.....	7
Vesta Fixture Wall Divider Panel Upright End & Intermediate.....	UFWDPU(OPT1)(NW)(NH)(OPT2).....	5
Vesta Fixture Divider Panel Upright Slotted End Frame.....	UFDPUSEF(NW)(NH)(OPT).....	6
Vesta Fixture Gondola Core.....	UFGC(NW)(NH)(OPT1)(OPT2).....	5
Vesta Fixture Shelf.....	UFUSA(OPT1)-(NW)(ND)-(OPT2).....	6
Vesta Fixture Upright Panel Frame, End & Intermediate.....	UFWDPU(OPT1)(NW)(NH)(OPT2).....	5

Part Number	Part Name	Page Number
<b>L</b>		
LLBB(NL).....	LEDge Light Versa Bus Bar.....	12
LLC5C(NL).....	LEDge Light Cat 5 Cable.....	14
LLC5CP.....	LEDge Light Cat 5 Coupler.....	14
LLC5SYS.....	LEDge Light Cat 5 Y-Splitter.....	14
LLCC38-25.....	LEDge Light Cable Clamp.....	10
LLDC.....	LEDge Light Dimming Controller.....	14
LLDCA.....	LEDge Light Dimming Controller Add-On Kit.....	13
LLDCS-(TYPE).....	LEDge Light Dimming Controller Starter Kit.....	13
LLHA.....	LEDge Light Harness Assembly.....	10
LLJ(NL).....	LEDge Light Jumper Cable.....	10
LLMS.....	LEDge Light Motion Sensor.....	14
LLMSA-(TYPE).....	LEDge Light Motion Sensor Add-On Kit.....	13
LLPS.....	LEDge Light Power Supply.....	10
LLS(NL).....	LEDge Light.....	9
LLSMB-(TYPE).....	LEDge Light Sensor Mounting Bracket.....	14
LLVC(ND).....	LEDge Light Versa Connector.....	12
LLVY.....	LEDge Light Versa Y-Connector.....	12
LUSA-(NW)(ND)-(OPT).....	Lighted Upper Shelf Assembly.....	7

Part Number	Part Name	Page Number
<b>T</b>		
TLMS(OPT1)(NW)(ND)-(OPT2)(OPT3).....	Tube Line Metal Shelf.....	8
TLUPODD(NW)1016(OPT).....	Tube Line Pull-Out Demo Display.....	8
TLUPODDEP(NH)1016(OPT).....	Tube Line Universal Pull-Out Demo Display End Panel.....	8

Part Number	Part Name	Page Number
<b>U</b>		
UFBD(NW)(ND)(NH).....	Vesta Fixture Base Drawer.....	7
UFDP(U)(OPT1)(NW)(NH)(OPT2).....	Vesta Fixture Upright Panel Frame, End & Intermediate.....	5
UFDPUSEF(NW)(NH)(OPT).....	Vesta Fixture Divider Panel Upright Slotted End Frame.....	6
UFDT(NW)(ND)(NH)(OPT1)(OPT2).....	Vesta Fixture Display Table.....	6
UFGC(NW)(NH)(OPT1)(OPT2).....	Vesta Fixture Gondola Core.....	5
UFGCSHS04.....	Vesta Fixture Gondola Core Sign Holder Stems.....	7
UFUSA(OPT1)-(NW)(ND)-(OPT2).....	Vesta Fixture Shelf.....	6
UFWDPU(OPT1)(NW)(NH)(OPT2).....	Vesta Fixture Wall Divider Panel Upright End & Intermediate.....	4



# About Madix

At Madix, we get it. You've got challenges. We have innovative answers to your merchandising and storage problems. For over 50 years we have listened to our customers and responded to their needs, focusing on the underlying issues they face to make their stores more profitable. We work one-on-one with each client to identify ways to improve store environments, which improves the bottom line. Madix offers an assortment of catalogued display and storage lines, and we love to design new products that tackle your specific needs. Madix draws on its experience to evaluate, consult, and share imaginative ways to make your sales floors and back rooms more productive. This interaction is what makes Madix stand out above all others as the innovative leader in the store fixture industry.

Learn more @ [www.madixinc.com](http://www.madixinc.com)



Texas 500 Airport Road, Terrell, TX 75160 | 800.776.2349  
Alabama 20984 Alabama Hwy. 9, Goodwater, AL 35072 | 800.633.6282